

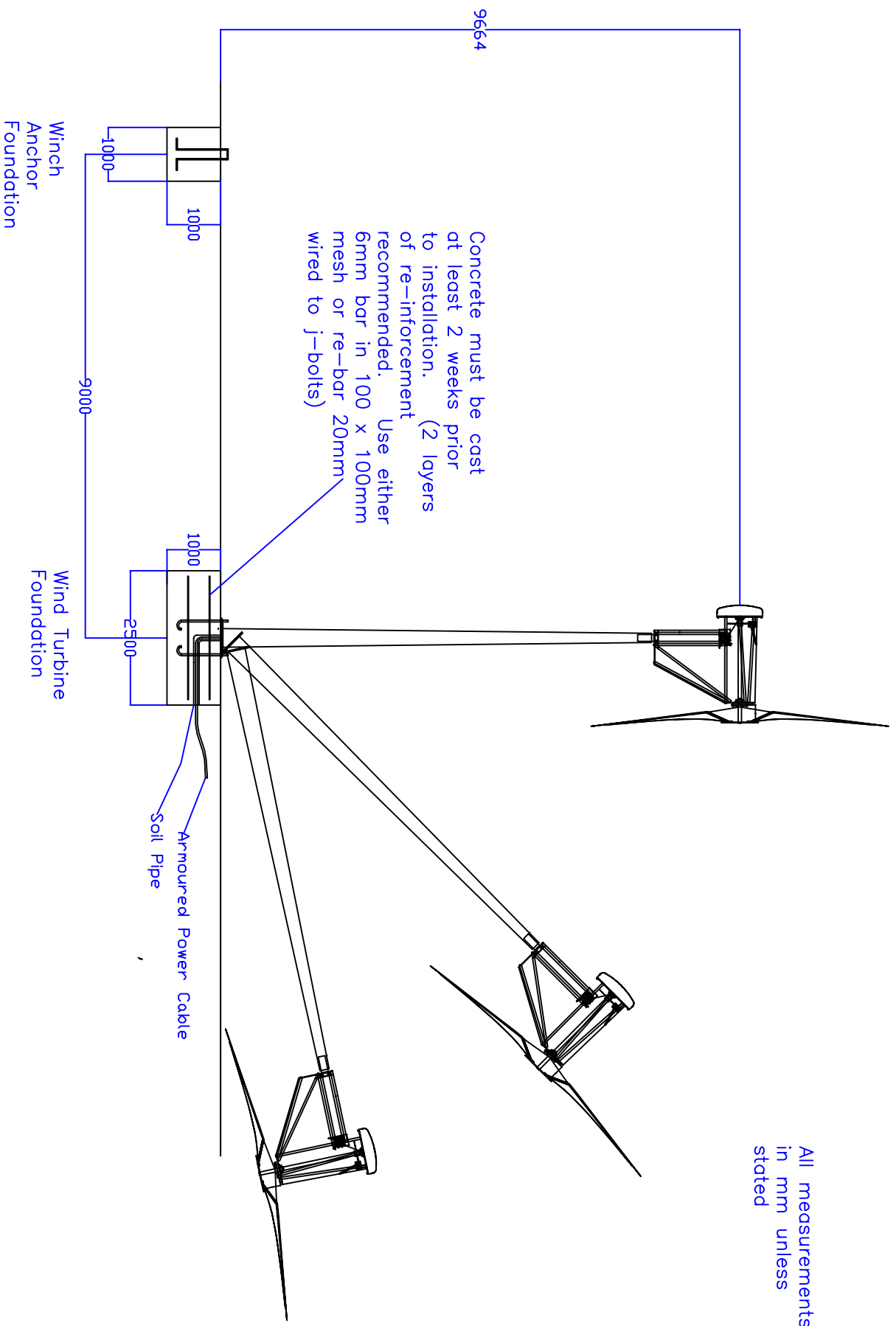

All measurements in mm unless stated

Concrete must be cast at least 2 weeks prior to installation. (2 layers of re-inforcement recommended. Use either 6mm bar in 100 x 100mm mesh or re-bar 20mm wired to j-bolts)



ZONE	REV	DESCRIPTION	REVISIONS	DATE	APPROVED	PREPARED BY BR	CHECKED BY	REV
-	-	-	-	-	-	FSCM NO.	DWG NO.	
-	-	-	-	-	-	6000 FO 006 rev 3.dwg	6000 FO 006 rev 3.dwg	
-	-	-	-	-	-	SCALE	DATE	08/10/03
-	-	-	-	-	-	SHEET	sheet	

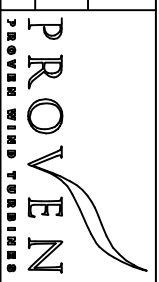

© Proven Engineering Products Ltd, Wardhead Park, Stewarton, Ayrshire, KA5 5LH, UK, Tel +44 1560 485 570 info@provenenergy.com All rights reserved
Proven WT6000 Turbine with TM900 Self Supporting Tilt Up Tower (Side Elev)

PROVEN TM900/WT6000 MAST FOUNDATION PREPARATIONS



The main foundation consists of a large block of high-strength concrete. Six lengths of M30 screwed rod are set into the concrete and are attached to the Foundation Base Plate. The Base Plate includes the hinge-pin attachment, which is used to raise and lower the turbine (see diagrams). Preferably, the concrete should be prepared and the foundation prepared with one load of concrete. Where this is not possible, the top layer should be added before the bottom one has had time to set.

Important

Before setting the Base Plate and foundations into the concrete foundation consider which way your WT will be lowered/raised and position the hinge-pin accordingly

Don't 'Shutter & Backfill'

When preparing house foundations a mould is prepared into which the concrete is poured. Earth/rocks are then filled around the foundation after the concrete has set.

For WT foundations it is better to have an irregular shaped foundation than to have a perfect cube and then surround it with loose earth - just dig a hole and then fill it! This will produce a foundation with good stability.

Preparing the Base Foundation

The base foundation consists of 6m³ of strong-mix concrete. Normally this is prepared as a rough 2.5 x 2.5 x 1m cube, but where ground conditions dictate, a shallower wider foundation of the same volume may be used.

Screw the 9 large (M24) bolts supplied with the base-plate it to their full extent (not transported this way to protect the end thread). The ends of the bolts are factory greased. These bolts will later be withdrawn and used to bolt the WT tower to the base plate. Inserting them at this stage makes sure there is the necessary clearance in the concrete.

Attach the M30 screwed rod with nuts provided to the base plate before pouring concrete. Insert reinforcing mesh into hole and jack up base plate assembly to approximately the right height. **It is very important that one of the M30 screwed rods at the hinge side of the base plate is set low into the concrete so that there will be access for the hinge pin to slide in later. If this is not done when the concrete is laid then the screwed rod should be hacksawed off just above the nut afterwards.** Insert conduit or soil pipe used for wind turbine power cable from edge of hole up through centre of base plate. Add concrete (Readimix supplier is usually easiest for this type of volume) and use vibrating concrete poker as necessary to remove air bubbles.

Use a spirit level and the nuts on the screwed rod to get the base plate flat. **It is vital that underneath the base plate is completely filled with concrete. The base plate must be fully supported by concrete when installation of turbine and tower takes place.** Leave the final tightening of the M30 nuts until the hardening period is over.

Clean the base plate of any excess concrete.

Proven Engineering Products Ltd Wardhead Park, Stewarton, Ayrshire, KA3 5LH, SCOTLAND
Tel: +44 (0) 1560 485 570 Fax: +44(0) 1560 485 580 info@provenenergy.com www.provenenergy.com

Winch Anchor Foundation

Refer to foundation diagrams for positioning. The anchor consists of a 1m cube or equivalent. It should be located on the opposite side of the base plate to the hinge pin attachment. **N.B. It is important that the anchor is placed exactly in line with the centre of the base plate and perpendicular to the line of the hinge brackets.** The pull on the anchor point for the WT6000/TM900 during raising and lowering is approximately 2500kg.

Concrete Specification

If using a Readimix supplier, ask for 35 Newton concrete. If mixing the concrete yourself, you should use the following proportions by volume

1:2:4
cement:sand:gravel

Approximate volumes and weights for a 1m³ foundation are

Cement:	310kg or 6.2 bags	(1 bag = 50kg)
Sand:	0.43m ³	(967 kg or approx 1.0 tonnes)
Gravel:	0.86m ³	(2150kg or approx 2.2 tonnes)

Hardening Time

You should allow plenty of time for the foundation to set and harden fully before erecting the turbine. We recommend a hardening period of approximately 2 weeks. For this reason, foundations are normally prepared in advance of the main installation. Note that the hardening time may be lengthened by poor weather conditions and shortened by the use of a quick-setting concrete additive.

Poor Foundation Preparations

Proven reserve the right to cancel an installation of a turbine if it is thought the foundations are of a poor quality. Subsequent costs in repairing the foundation and any further site visits will be met by the customer.



20 mm mild steel

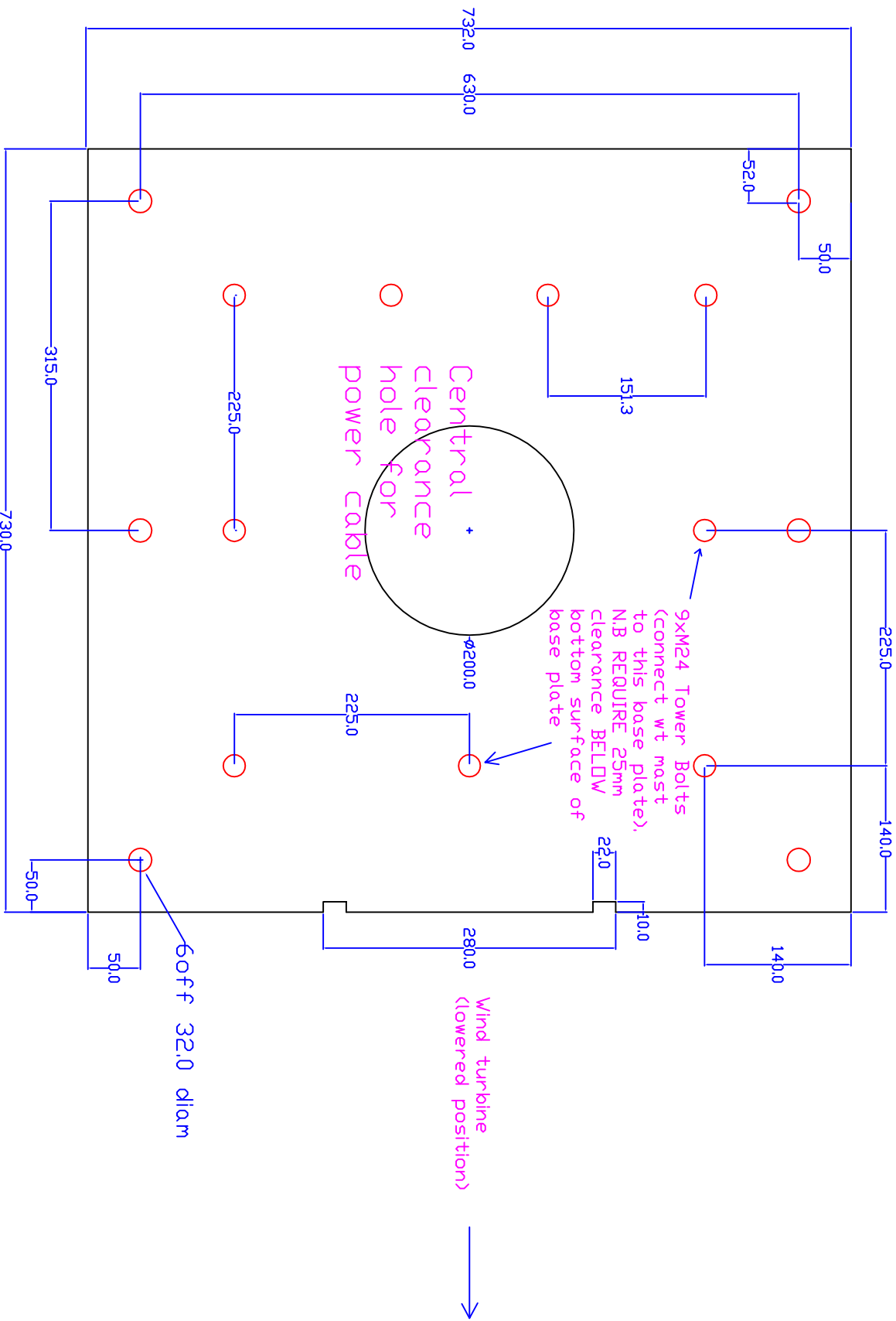

ZONE	REV	DESCRIPTION	REVISIONS	DATE	APPROVED	PREPARED BY RC	CHECKED BY	SCALE	DATE	REV
-	-	-	-	-	-	FSCM NO.	DWG NO.	6000 FO 027.dwg	9 September 2003	1
-	-	-	-	-	-	6000 FO 027.dwg	sheet	1	9 September 2003	1
-	-	-	-	-	-	6000 FO 027.dwg	sheet	1	9 September 2003	1

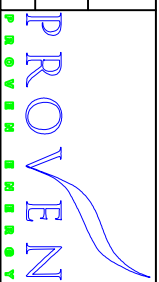

© Proven Engineering Products Ltd, Warhead Park, Stewarson, KAS 5LH, UK, Tel: +44 1560 485 570, info@provenenergy.com, All rights reserved

Drawing Title: WT6000/TM900 Baseplate Drawing



Proven Engineering Products Ltd, Wardhead Park, Stewarton, Ayrshire, KA3 5LH, Scotland.
Tel. +44 (0)1560 485 570 Fax +44 (0)1560 485 580 E-mail: info@provenenergy.com Web: www.provenenergy.com

Foundation Pack for WT6000/TM900

LIST OF PARTS TO BE SENT WITH BASE PLATE

- 1 - GALVANISED BASE PLATE
- 6 - FOUNDATION RODS, WITH 12 NUTS AND 6 WASHERS
- 9 - M24 HIGH TENSILE BOLTS AND 9 WASHERS
- 1 - ANCHOR PIN
- 1 set Foundation Pack
 - 1 Pack Description (this page)
 - 1 Standard foundation diagram
 - 1 Anchor foundation diagram
 - 1 Alignment/Access diagram
 - 1 Foundation description (incl. concrete mixing details)

N.B. REINFORCING STEEL MESH SHEET IS ALSO REQUIRED FOR THE FOUNDATION WORK BUT IS NOT INCLUDED IN THE KIT SUPPLIED BY PROVEN